

BIANCO **iCON** SERIES **DRIVES**

Bia iDrive 3220	PN 802673
Bia iDrive 3400	PN 802674
Bia iDrive 3550	PN 802675
Bia iDrive 3750	PN 802676
Bia iDrive 31100	PN 803188
Bia iDrive 31500	PN 803189
Bia iDrive 31850	PN 803190



1. Contents

1. Contents	2
2. Introduction	4
3. Key Features, Protections and Conformities	4
4. Function Descriptions	5
5. Technical Specifications	6
6. ISO 7010 Symbols used in this manual	6
7. Warnings and Cautions	7
8. Electrical Connections	8
Main PCB Power connection - Lower main PCB	8
Control circuit Wiring Connections – Upper PCB	8
Input Signal Selection Array	8
9. Function Terminals – Wiring and Description	9
10. Display	10
Viewing Current Operating Values	10
11. Display Functions Explained	11
12. Controller Programming	12
13. Initial setup	13
14. Exiting Programming Mode	14
15. Transducer Tuning	14
16. System Sleep Mode	14
17. Wiring - Summary	15
18. Minimising EMI	15
19. Application Example 1: Pump (water supply mode) providing constant pressure. Outlet side pressure transducer ONLY	16
20. Application Example 2: iDrive operation without a pressure transducer. (Soft starter)	17
21. Application Example 3: Manual/Auto control wiring	17
22. Application Example 4: Pump with outlet transducer (water supply mode providing constant pressure) and fitted with external water level float and/or external run and fault indicator	18
23. Application Example 5: Terminal Run/Stop wiring and settings. Fitting an inlet pressure transducer (water supply mode providing constant pressure)	19
24. Application Example 6: Pump (water supply mode providing constant pressure) using an outlet side Electric Contact Gauge or Pressure switch	20
25. Application Example 7: Day Part run time	21
26. Minimum Frequency Considerations	23

27. Multi Pump Control Wiring	24
28. Multi Pump Control Programming	25
Master Controller Setup.....	25
28. Multi Pump Control Programming Con't	26
Auxiliary Controller Setup.....	26
Terminal Run/Stop and Auto/Manual Switching	26
29. Application Example 8: 'Pumping' Applications	27
30. Programming Groups and Parameter Details	29
br-00 Application Group	29
br-01 Running Parameter Group	29
br-01 Running Parameter Group continued	30
br-02 PID Parameter Group.....	30
br-02 PID Parameter Group Continued	31
br-03 Multi Pump Control Parameter Group	32
br-04 Sleeping Function Parameter Group	33
br-05 Control Parameter Group.....	34
br-05 Control Parameter Group continued.....	35
br-06 Interface Parameter Group	35
br-06 Interface Parameter Group continued – Fault codes	36
br-07 Day Part Running Parameter Group	37
br-08 Motor Parameter Group.....	38
31. Controller Error Code Trouble Shooting Guide	39
32. Controller Error Code Trouble Shooting Guide Con't	40
33. Faults and Trouble Shooting Guide	41
34. Maintenance	42
35. Warranties – Terms and Conditions	43

2. Introduction

Congratulations on the purchase of your iCon iDrive Variable Frequency Controller.

The iCON iDrive series are designed and built from the ground up as a pump-specific variable frequency controller. The iDrive is easy to program and operate. It is equipped with an easy to understand LCD display, has its own cooling fans fitted and comes with a mounting bracket for remote mounting.

The iCON iDrive VFD conserves energy by only operating the pump at the speed required to maintain set-point pressure. Great for systems with variable demand. It can operate automatically in conjunction with up to 5 other drives in a multiple pump set.

The iCON iDrive eliminates the requirement for large, costly pressure tanks and eliminates the associated pressure cycling that occurs with a traditional pressure switch control system.

3. Key Features, Protections and Conformities

Features:

- Constant water pressure.
- Optimised pump performance.
- Soft start, low motor start current.
- Multi-pump control. 1 master and up to 5 auxiliary controllers
- Master Fault Shift automatically. Moves control to nominated auxiliary if Master faults.
- Alternate running to balance pump run times
- Freeze proofing function
- Anti-clogging function

In built Pump Protections:

- Dry run protection.
- High and low voltage protection.
- Input and output short circuit protection.
- High and low water pressure protection.
- Input and output phase failure protection.
- Over temperature protection.
- Sensor fault protection.

Conformity:

- Verification of EMC compliance certificate no. AC/0410709 to EN 61326-1:2006, EN 61000-3-2:2005, EN 61000/3/3:1995+A1:2001+A2:2005.
- Verification of LVD compliance certificate no. AC/0420709 to EN 61010-1:2001.

4. Function Descriptions





	Action	Factory Setting
Sleep Function <i>b04.00 to validate</i> <i>Tune via Parameter Group br-04</i>	<p>When there is no water demand the pump will decelerate to the minimum frequency.</p> <p>Following a detection cycle the controller will enter sleep mode and stop the pump.</p> <p>When the pressure drops below the user-set parameter value the controller will wake up automatically and restart the pump.</p>	Valid
Restart After Power On <i>b01.16 to validate</i>	<p>In the event of a controller power interruption, with this setting VALID, normal operation will resume automatically when power is restored.</p>	Invalid
Anti-clogging Function <i>b00.04 to validate</i> <i>b00.05, b00.06 and b01.04 to tune</i>	<p>Once this setting is made VALID, when the pump shuts down a user programmable sequence runs the pump first in reverse, then forward at a set speed and for a set time.</p> <p>Designed for a single pump</p>	Invalid
Day-Part Control <i>Parameter Group br-07</i>	<p>Divide one day into separate parts to vary pressure as desired. Incorporates an input side water pressure limit. If the input water pressure is less than the setting pressure the pump will stop running until inlet pressure recovers.</p>	Invalid
Terminal Run/Stop <i>b05.02 to validate</i>	<p>The controller can be operated by an external switch or input. When switched on the pump will run normally at constant pressure. When the external switch is turned off the pump will stop.</p> <p>The switch can be located remotely</p>	Invalid
Manual/Auto Control <i>b05.02 to validate</i>	<p>Using an external switch or input, the pump will run at full frequency. When the switch is turned off the controller returns to normal variable frequency, operation.</p> <p>The switch can be located remotely</p>	Invalid
Electric Contact Control <i>b05.02 to validate</i>	<p>Two terminals switch between S1/S2 COM and instruct the controller to accelerate or decelerate respectively.</p> <p>Can be used for a pump running within a switch setting pressure range.</p>	Invalid

5. Technical Specifications

Function	Variable speed, Constant pressure Water supply
Modes	Single or multi pump control Synchronous or Master/Slave
Power Supply Voltage	380V +/- 15%% 3 ph 50/60Hz (323 to 437V)
Output frequency range	0 – 50/60Hz
Working temp range	0 - 40°C De-rate the controller at air temps over 40 deg C and at altitudes exceeding 1000m above sea level
Working humidity range	20 – 90%
IP Rating	IP55
Dimensions	Bia iDrive 3220 192 (H) x 200 (W) x 151 (D) Bia iDrive 3400 ~ 3750 282 (H) x 255 (W) x 160 (D) Bia iDrive 31100 ~ 31850 380 (H) x 350 (W) x 250 (D)

Model No.	B603B Model ID	Rated Input Current (A)	Rated Output Current (A)	Nominal Motor Current (kW)
Bia iDrive 3220	B603B-4003	5.8	5.0	2.2
Bia iDrive 3400	B603B-4005	10.0	9.0	4.0
Bia iDrive 3550	B603B-4007	15.0	13.0	5.5
Bia iDrive 3750	B603B-4010	20.0	17.0	7.5
Bia iDrive 31100	B603B-4003	26.0	25.0	11.0
Bia iDrive 31500	B603B-4003	35.0	32.0	15.0
Bia iDrive 31850	B603B-4003	38.0	37.0	18.5

6. ISO 7010 Symbols used in this manual

	Warning - Electrical safety
	Warning – Potential consequences of use outside of intended application(s). Includes environmental condition warnings.
	Mandatory warning
	Warning to disconnect power
	Read carefully

7. Warnings and Cautions

	<p>Read the manual carefully before starting and retain for future reference.</p>
	<p>Prior to starting installation or maintenance the controller must be disconnected from the power supply. Allow 5 minutes for the internal electronics to discharge before opening the cover</p>
	<p>Any changes or modification to the wiring must be carried out by competent, skilled and suitably qualified personnel only.</p>
	<p>A qualified electrician should correctly size and install circuit breakers to protect the power supply. The fitment of additional surge protection is recommended.</p>
	<p>Never open the cover while controller is connected to electrical supply. Disconnect and allow 5 minutes for the internal electronics to discharge before opening the cover</p>
	<p>This appliance is not intended for use by persons (including children) with reduced physical, sensory or mental capabilities, or lack of experience and knowledge, unless they have been given supervision or instruction concerning use of the appliance by a person responsible for their safety. Children should be supervised to ensure that they do not play with the appliance.</p>
	<p>Ensure the controller is a suitable size for the pump motor (see Section 5. Technical Data). Size according to P1 power.</p>
	<p>Avoid installing the iCon iDrive where it could experience the following conditions:</p> <ol style="list-style-type: none"> i. Where there is significant vibration and/or mechanical shock. ii. Where it could be exposed to corrosive liquids or gasses, or to flammable materials, solvents etc. iii. Extreme heat and cold. Operating range 0°C - 40°C. iv. Protect the controller from rain, moisture, humidity or dust

8. Electrical Connections

Install with a suitably rated circuit breaker

All wiring must be carried out by a suitably qualified technician.



Main PCB Power connection - Lower main PCB

Note: Never connect AC power to UVW terminals

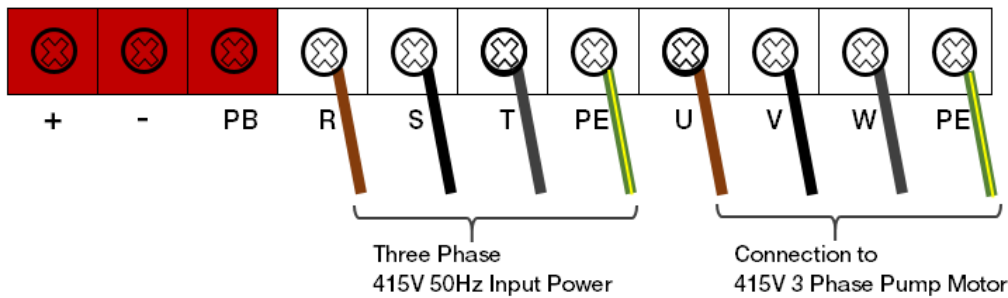

Control circuit Wiring Connections – Upper PCB

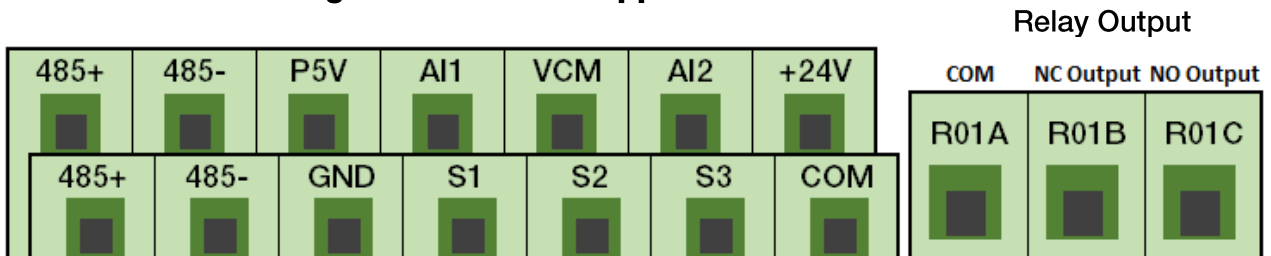

Input Signal Selection Array – Upper PCB to the left of the Control circuit connection block

Jumper positions

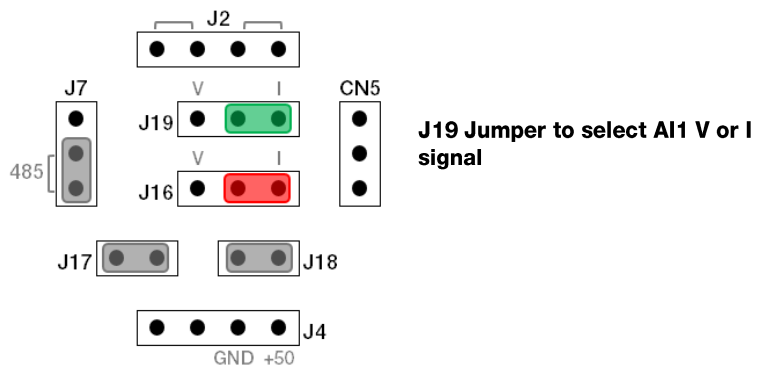

9. Function Terminals – Wiring and Description

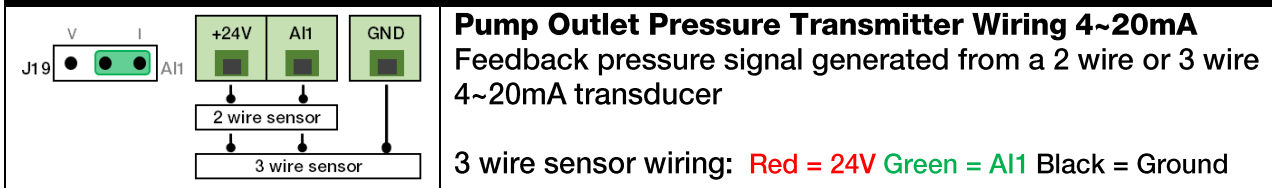

Note: The factory default programming assumes the use of a 4~20mA transducer on the pressure side of the pump to achieve control feedback.

For convenience, the controller default (**b02.08**) is set with a non-zero 'AI1 Feedback Lost Detecting Value'. If no pressure signal feedback into the terminal AI1 is detected, the controller will display "E022" upon start up. Connect a transducer to the controller then press the **STOP/RST** key.

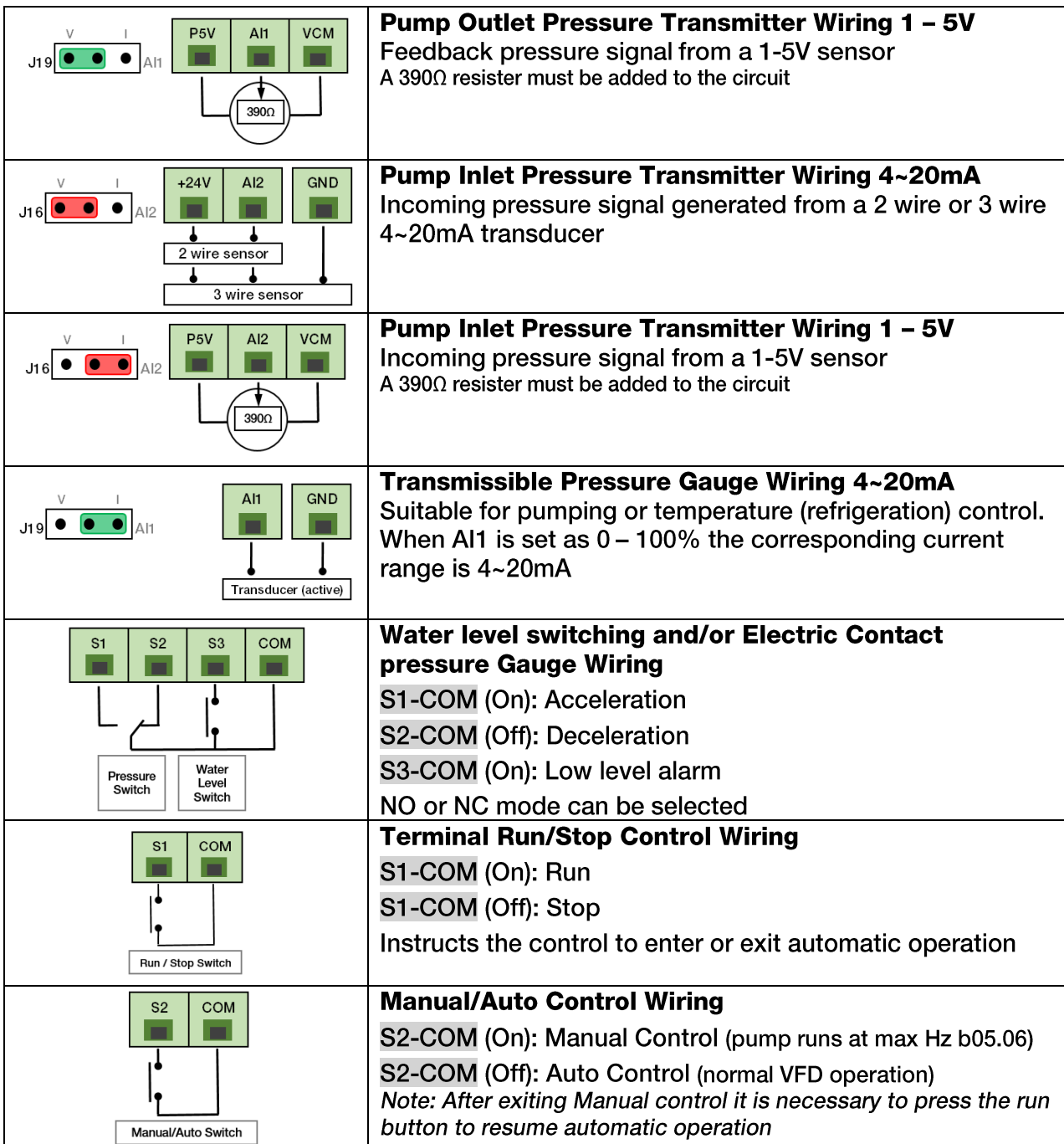

10. Display

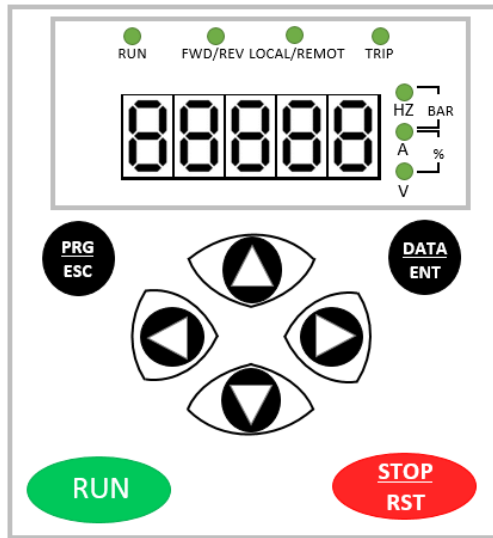

Viewing Current Operating Values (Top level)

Navigate using  

Standby Mode



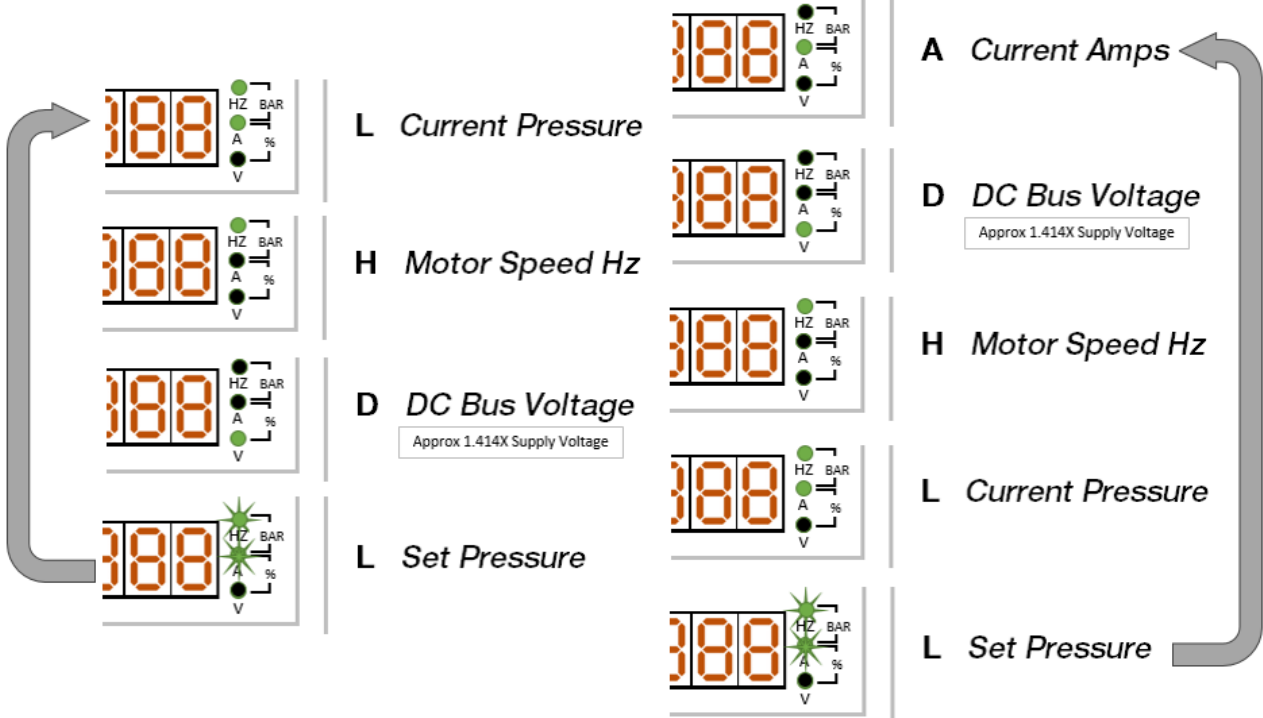

Run Mode



The operating set point pressure can be altered at any time using the UP and DOWN buttons. Any changes in this manner are not saved to parameter **b00.01** unless **DATA/ENTER** is pressed to lock in the change.



11. Display Functions Explained

Element Function	Explanation
RUN LED	Light on: Operational status Light off: Stop or standby status
FWD/REV LED	Light on: Reverse Operation Light off: Forward Operation
LOCAL/REMOT LED	Light on: Auxiliary Controller Light off: Master controller
TRIP LED	Light on: Active Fault Status Light off: Normal operation
Hz LED	Flickering or light on when displaying frequency
A LED	Light on when displaying current
V LED	Light on when displaying (internal DC bus) voltage
BAR - LED PAIR	LED's steady = Current pressure value displayed LED's flashing = Programmed set pressure value displayed
% - LED PAIR	Both LED's illuminated when displaying percentage
DIGITAL DISPLAY	5 digit LED screen displaying operating values, parameter settings and alarm codes
	Enter Programming mode from Top Level ALSO Undo previous button press / level up
	Progressively enter menu AND confirm parameters
UP	Under normal (non-programming) operation the UP and DOWN buttons alter the pump operating pressure parameter <u>without</u> entering programming mode.
DOWN	In programming mode the UP and DOWN buttons are used to increase or decrease the relevant value on display
LEFT SHIFT	In normal (non-programming) operation the left and right shift buttons cycle through the display options
RIGHT SHIFT	In programming mode the left and right shift buttons move the cursor to the digit to be altered
	Instructs the controller to enter operational status. Green LED RUN (top left) will illuminate
	Instructs the controller to exit operational status. In the event of an fault/error code, pressing STOP/RST will clear the fault and allow the controller to resume normal operation

12. Controller Programming

Until users are familiar with navigating the programming menu it can be difficult to register whereabouts in the program you are.

At any time, pressing the PRG/ESC button repeatedly (up to 3 times) will return you to the Top Level

Once in the programming menu the format of the display provides a clear indicator.

At Level 2 the desired parameter group can be selected. The display will indicate **br00 – br07**

Once entering a parameter group into Level 3 the display is subtly different i.e. **b01.09** etc.

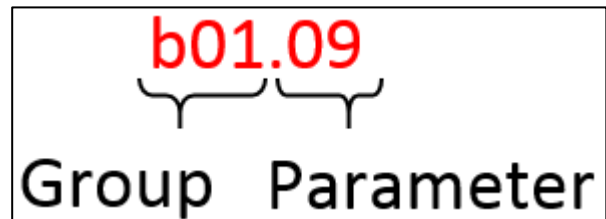

Group	Application	Running	PID	Reserved	Sleeping	Control	Interface	Day Part	Motor
Level 2	br-00	br-01	br02	br03	br04	br05	br06	br07	br08
Level 3	b00.00 b00.01 b00.02 b00.03 b00.04 b00.05 b00.06	b01.00 b01.01 b01.02 b01.03 b01.04 b01.05 b01.06 b01.07 b01.08 b01.09 b01.10 b01.11 b01.12 b01.13 b01.14 b01.15 b01.16 b01.17	b02.00 b02.01 b02.02 b02.03 b02.04 b02.05 b02.06 b02.07 b02.08 b02.09 b02.10	b03.00 b03.01 b03.02 b03.03 b03.04 b03.05 b03.06 b03.07 b03.08 b03.09	b04.00 b04.01 b04.02 b04.03 b04.04 b04.05 b04.06	b05.00 b05.01 b05.02 b05.03 b05.04 b05.05 b05.06 b05.07 b05.08 b05.09	b06.00 b06.01 b06.02 b06.03 b06.04 b06.05 b06.06 b06.07 b06.08 b06.09	b07.00 b07.01 b07.02 b07.03 b07.04 b07.05 b07.06 b07.07 b07.08 b07.09 b07.10 b07.11 b07.12 b07.13 b07.14 b07.15	b08.00 b08.01 b08.02 b08.03 b08.04 b08.05 b08.06 b08.07

Entering programming mode

- Set the controller to standby mode by pressing **STOP/RST**.
- The Green LED **RUN** (top LH of display) will be dark.
- Press **PRG/ESC** then **DATA/ENT**. The display will read **b00.00**
- Press **DATA/ENT**. The display will read **00000** (the RH zero will be flashing). *If the RH zero isn't flashing, press **STOP/RST***
- Using **^** **V** buttons to increase/decrease values and the **<** **>** buttons to scroll sideways
- Enter (default password) **65535**
- Press **DATA/ENT** and Groups br-01 to br-07 are unlocked. The display will read **b00.01**
- Press **PRG/ESC** to return to Level 2.

13. Initial setup

Before use, it is critical that the motor Nameplate information is programmed into the Controller at parameter addresses b08.01 – b08.05

Note that Parameter Group 8 is password protected.

To enter Parameter Group 8, navigate to **br07** and then to **b07.15**

Press **DATA/ENT**. The display will read **00000** (the RH zero will be flashing).

*If the RH zero isn't flashing, press **STOP/RST**.*

Using **Λ V** buttons to increase/decrease values and the **< >** buttons to scroll sideways,

Enter (default password) **65535**

Press **DATA/ENT**. The display will now read **b07.01**

Press **PROG/ESC** to return to Level 2. Navigate to **br-08** and press **DATA/ENT**.

The display will read **b08.00**. Using **Λ V** buttons navigate through b08.01 – b08.05 and enter the correct values taken from the motor nameplate information.

br-08 Motor Parameter Group			
<i>Group br08 is locked behind an additional password</i>			
<i>Go to br07.15 and enter the password set at b06.09 (Default password is 65535)</i>			
<i>This is the same as the default password used at b00.00 to enter the programming menu.</i>			
Name	Setting Range	Factory Default	Description
Motor rated Power	0.4~350 kW	Model Set	Enter settings from the motor nameplate The Over Voltage OV and Over Current OC protection is derived from the values entered in parameters b08.01 – b08.05
Motor rated Frequency	0.01~600 Hertz	50Hz	Pump power ratings are most commonly referenced from the P2 (Shaft Power) rating.
Motor rated Speed	0~36000 RPM	Model Set	The Controller interacts with the motor so the B08.01 value should be the P1 rating.
Motor rated Voltage	0~460 Volts		If the P1 rating is not on the motor name plate, for single phase pumps this equation will provide an approximation:
Motor Rated Current	0.1~2000.0 Amps		<i>(Rated Voltage x Full load Current Amps) x 0.9 = Wattage</i>

Take care not to alter b08.00, b08.06 or b08.07



Programming should only be carried out by suitably trained personnel. Parameters randomly modified or altered in error can induce abnormal operation and have the potential to harm the controller as well as the water supply system, or even to cause personal injury or accidents.

14. Exiting Programming Mode

Navigate to **b00.00** Press **DATA/ENT**. The display will read **00000** (the RH zero will be flashing).

Press **DATA/ENT** to accept this value OR enter an otherwise invalid password i.e. **00001**

The display will read now **b00.00** but it is no longer possible to navigate within Level 3, nor Level 2 after pressing **PRG/ESC**.

Press **PRG/ESC** to return to the Top Level.

15. Transducer Tuning

The pressure value displayed on the controller may differ from a quality analogue pressure gauge. A display value less than the actual pressure can create issues.

If the controller is trying to achieve greater pressure than the pump can deliver due to an inaccurate digital reading, the controller tuning becomes much harder.

The Running Parameter Group br-01, and specifically parameters b01.06 – b01.14, can be used to ensure the digital signal matches an analogue reading. This is highly recommended.

16. System Sleep Mode

As the water demand falls the controller reduces the pump operating speed.

With the Sleeping Function Group operational (**b04.00** - select 1 to validate) once minimum frequency is reached (**b05.07**), after the sleeping wait time is exceeded the controller will begin its sleep down cycle.

The output frequency will 'dip' 3 times according to the setting of **b04.02** - which is a relative percentage of the rated frequency **b08.02**

If pressure is maintained throughout the shutdown cycle the controller reasonably assumes flow has ceased and will enter sleep mode.

The pump will recommence operation once the Wake up pressure bias is exceeded.

If the pump is unable to maintain its operating set point pressure **b00.01** throughout this cycle it will not shut down and will continue to run at the set minimum frequency.

This situation can occur when the pump curve is very flat.

In this situation you have 3 options:

Decrease the operational set point pressure **b00.01**

Increase the minimum frequency **b05.07**

Reduce the Sleeping test Frequency Proportion / Water Testing **b04.02**.

An unwillingness to sleep can also be the result of leaks in the system.

17. Wiring - Summary

3 Phase 380V +/- 15% 50/60 Hz to R,S,T

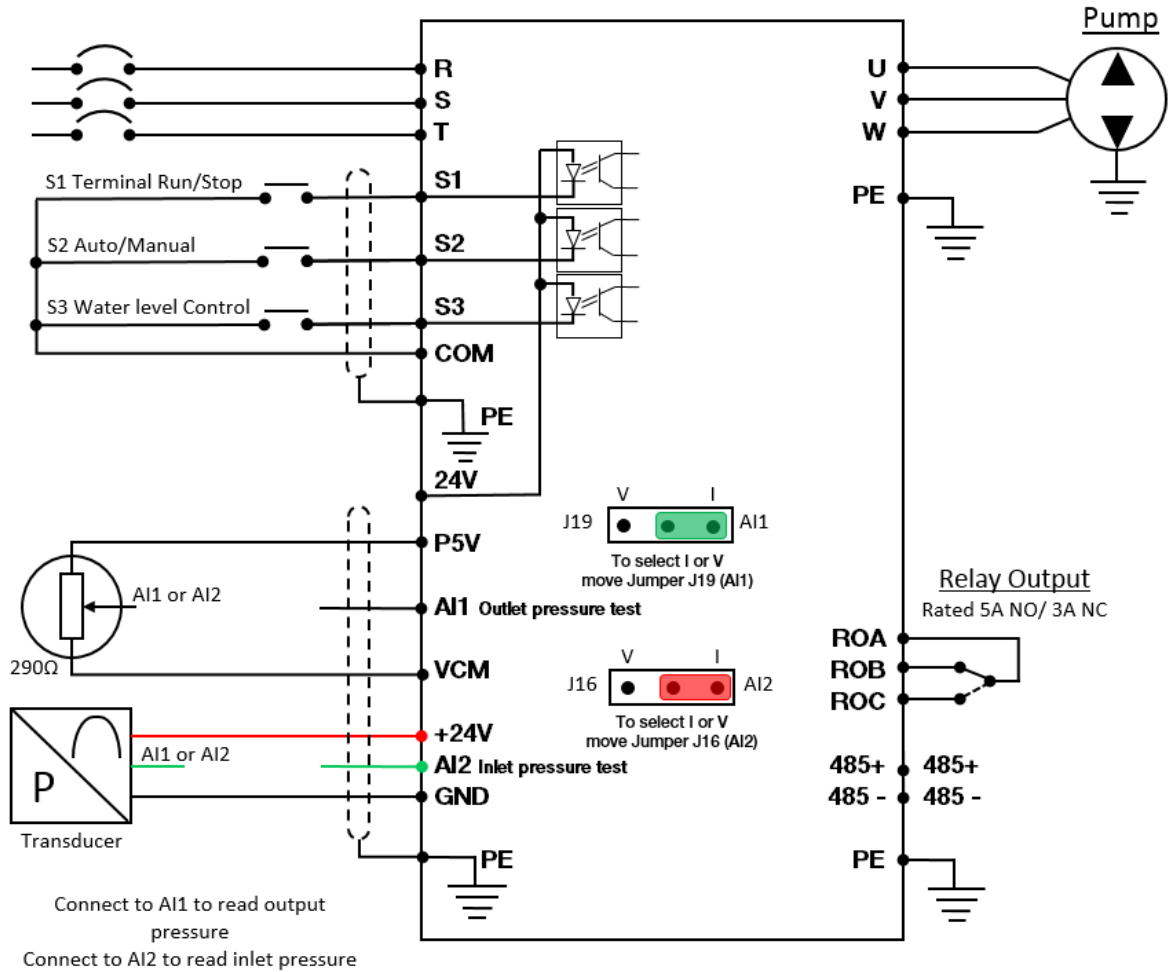

18. Minimising EMI

To minimise the effect of EMI (Electromagnetic Interference), for signal conductors it is recommended to use Twisted Pair and Shielded cable.

Alternately, use single conductors and twist to provide a balanced capacitance and inductive coupling thus cancelling out differential mode interference.

Installing shielded power cable is the most effective means to alleviate EMI problems. The cable's shield forces the noise current to flow directly back to the VFD before it gets back into the power network or takes other undesirable and unpredictable high frequency paths. Unlike signal wiring, the shielding on the motor cable should be terminated at both ends

If shielded cable is not available then conductors plus ground in a conduit will provide some degree of protection.

The importance of good grounding cannot be overstated. Of all of the methods to mitigate EMC issues, grounding is the most effective and least costly.

The ground wire should be big (>3.5mm²) and short.

19. Application Example 1: Pump (water supply mode) providing constant pressure. Outlet side pressure transducer ONLY

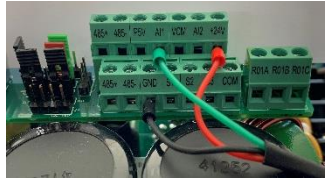
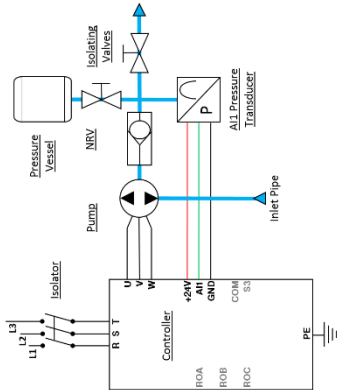
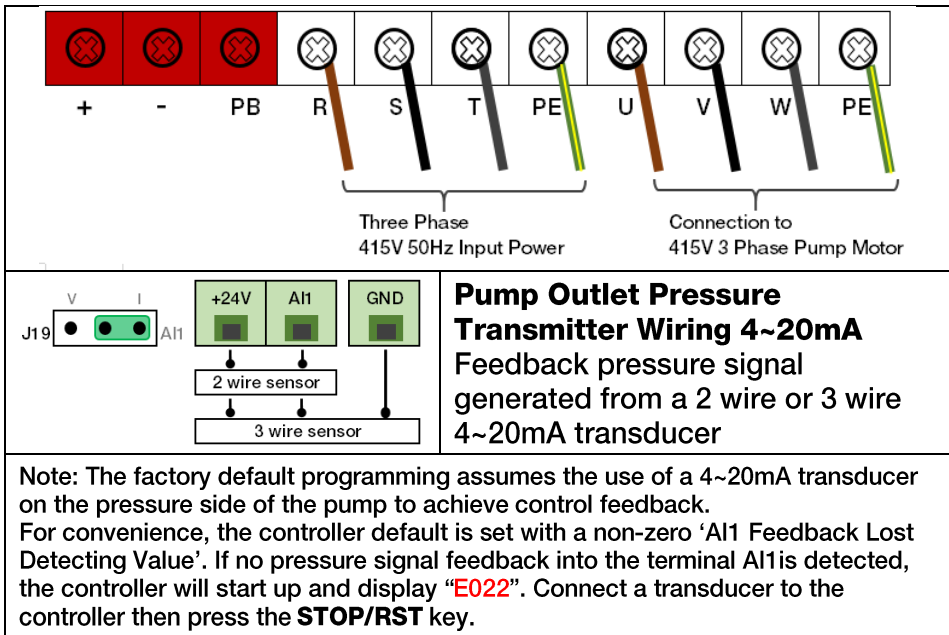

Note: The factory default programming assumes the use of a 4~20mA transducer on the pressure side of the pump to achieve control feedback. For convenience, the controller default is set with a non-zero 'AI1 Feedback Lost Detecting Value'. If no pressure signal feedback into the terminal AI1 is detected, the controller will start up and display "E022". Connect a transducer to the controller then press the **STOP/RST** key.

- Mount controller securely
- Connect Controller to pump motor
- Connect transducer to controller
- Connect Power to controller
- **Set motor nameplate parameters in Group br-08 (b08.01 – b08.05)**
- Program recommended start values as below:

b00.01	Operational pressure	As per your requirement
b00.02	Motor Direction	As default (0) unless required (CONFIRM DIRECTION ON COMMISSIONING)
b00.04	System anti block	Set to 0
b01.02	Low Pressure running time	Set according to your requirements
b01.16	System Auto Restart	Set to 1
b04.00	System sleep mode	Set to 1
b04.01	Sleep delay in seconds	Set to 5.00
Pg 33	Sleep Wake up Differential	Suggest 0.5 bar pressure drop
b05.00	Water Level control	Set to 0 if none fitted
b05.03	Acceleration time	Suggest 5.0 seconds, 1 sec for bore motor
b05.04	Deceleration time	Suggest 5.0 seconds, 1 sec for bore motor
b05.07	Lower Frequency Limit	Pump dependant. Keep borehole pumps above 35Hz minimum. Pump must achieve set-point pressure at min Hz to initiate sleep mode

- Expel air from the system (throttle using discharge valve)
- Check direction of pump rotation
- Tune the transducer reading if necessary (b01.06 – b01.14)
- Ensure pump can maintain set point pressure and will enter sleep mode (min and max Hz may need adjusted)

Run the pump and set the discharge valve as required.

20. Application Example 2: iDrive operation without a pressure transducer. (Soft starter)

It is possible to use the iDrive as a 'Soft starter' or to operate the drive with a fault in the Pressure Transducer.

The pump will run at the maximum Hz setting (b05.06) but will respect the acceleration and deceleration settings (b05.03 and b05.04).

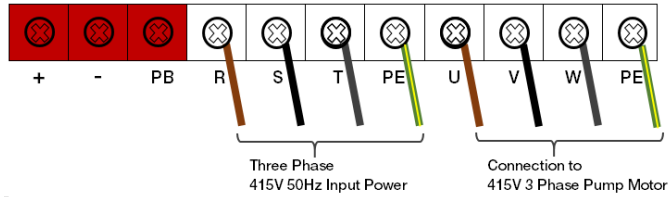

Method.

- Ensure the controller is in standby mode by pressing **STOP/RST**. The **Green LED RUN** (located top left) will be dark.
- Enter Programming mode (see [Section 12, Page 12](#))
- Alter the following parameters

b01.01	Low Water Pressure Alarm Value	Set to 0.0 bar
b02.08	(AI1 Feedback Lost detecting value)	Set to 0.0% from default of 1.0%

- Exit programming mode

Note that the controller will not enter sleep mode with the transducer disabled. Some form of manual ON/Off control is required.

21. Application Example 3: Manual/Auto control wiring.

Suitable for situations where it is desirable to manually switch to full frequency operation such as pipe filling or where maximum pump performance is desired for a period of time.

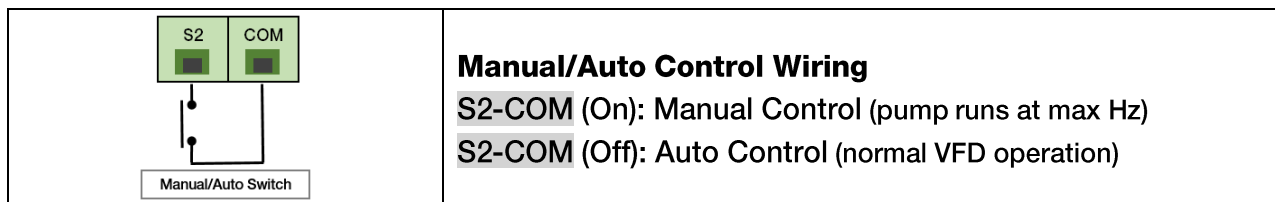

Connect an external switch between **S2** and **COM**.

b05.02 S2 Terminal Control	Set to 2 = Manual/Auto Control Default: 0 = Invalid	S2-COM (Off): Auto Control Constant water pressure control mode (b00.01) S2-COM (On): Manual Control Full frequency Running (b05.06)
-------------------------------	--	---

When switching from manual control back to automatic control it is necessary to press RUN to set the controller to Operational mode.

22. Application Example 4: Pump with outlet transducer (water supply mode providing constant pressure) and fitted with external water level float and/or external run and fault indicator

Set up as per Example 1. PUMP WITH TRANSDUCER ONLY See Pg 16

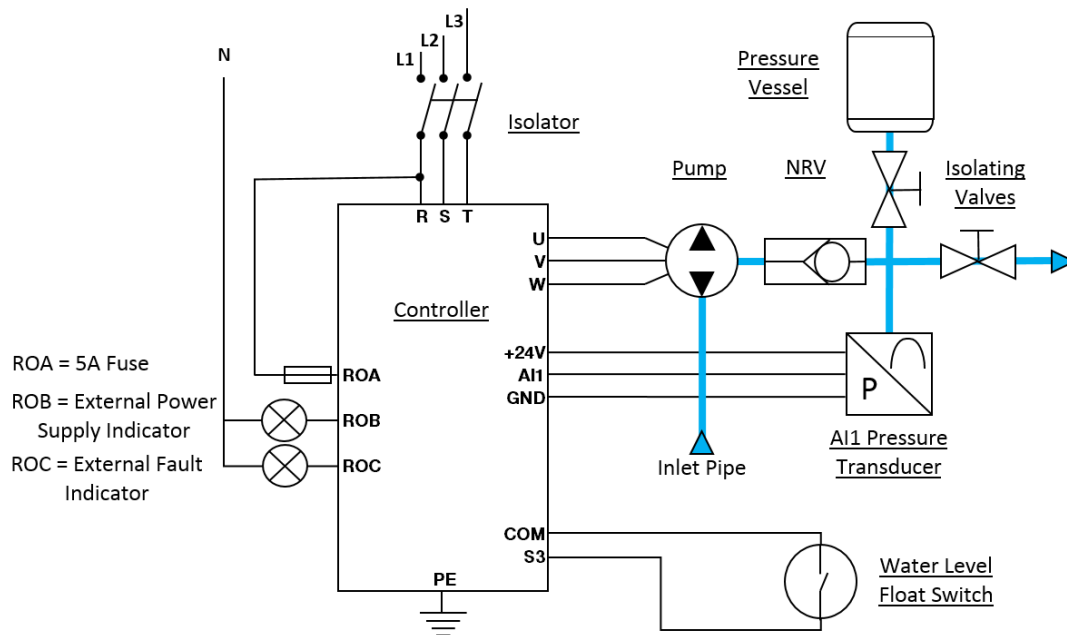

- Connect external devices
- Program parameters generally as per Pg 16 Example 1 and specifically as below:

b01.01	Factory setting 0.5 (Bar)	Low water pressure OR Low water level (sensor) setting
b05.00	Factory setting 0 (invalid)	Terminal S3 switch type 1: NC Valid 2: NO valid
b05.01	Factory setting 001 (Minutes)	S3 Action delay time. Set delay to prevent excessive on/off events
b05.09	Factory setting 00 (Hours)	Low pressure restart delay time. Pump will restart after set number of hours. 00 = invalid

- Check operation of water level switch/float
- Erase error log of commissioning faults (b07.14) Set to 2, Press **DATA/ENT** to clear

23. Application Example 5: Terminal Run/Stop wiring and settings. Fitting an inlet pressure transducer (water supply mode providing constant pressure)

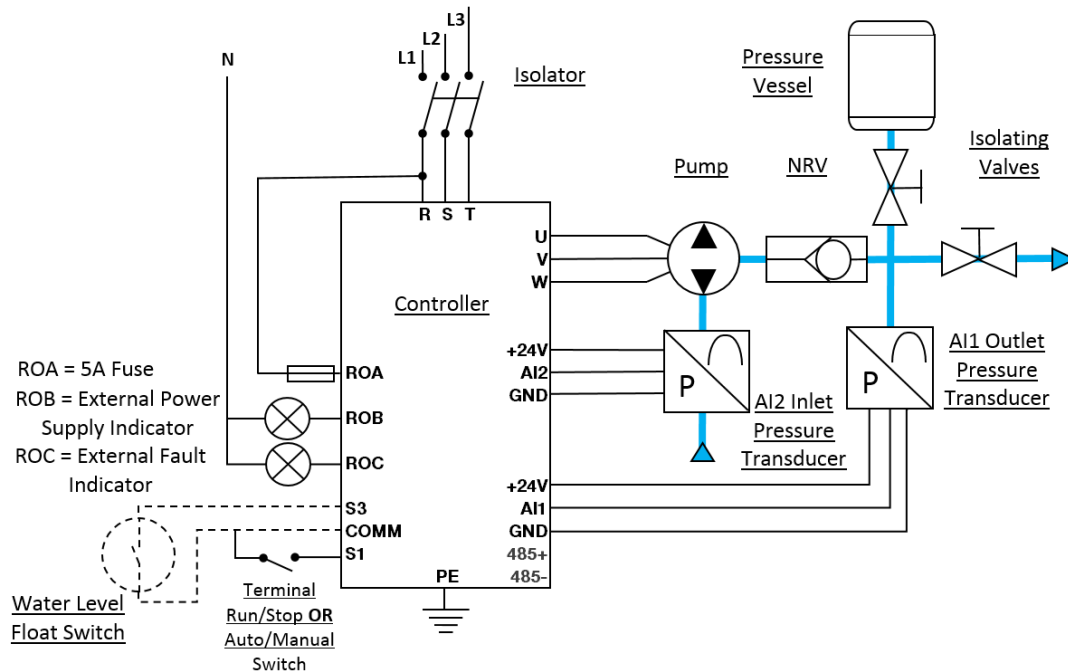

Connecting a switch between **S1** and **COM** allows for remote ON/OFF switching OR Auto/Manual Control.

- A shielded, twisted pair is recommended to wire the switch
- Set parameter **b05.02** to 3 to validate. ON/OFF Switching
Switch on = the pump will run. Switch off = the pump will stop
- When a switch is installed between **S1** and **COM** the **RUN** and **STOP/RST** buttons on the controller are no longer active

A level control switch can be included between **S3** and **COM** if required.

- Use Parameter **b05.00** to select NC or NO switch signal
1 = NC, 2 = NO, 0 = Invalid
- Parameter **b05.01** enables a delay time to be selected to prevent excessive stop/start in the event of rapid switching signal to S3

An inlet pressure transducer can be connected to terminal **AI2**

- Set **b02.09** AI2 Feedback Lost Detecting value to 1.0% to enable the controller to register Inlet transducer errors
- Set the Inlet Low Pressure value at parameter **b07.13**
The pump will shut down if the inlet pressure falls below this value and will resume operation when the pressure rises again above the set value
- Low inlet pressure does not trigger a LP alarm

When programming is finished and the error log erased, press **RUN** to set the unit to Standby.

24. Application Example 6: Pump (water supply mode providing constant pressure) using an outlet side Electric Contact Gauge or Pressure switch

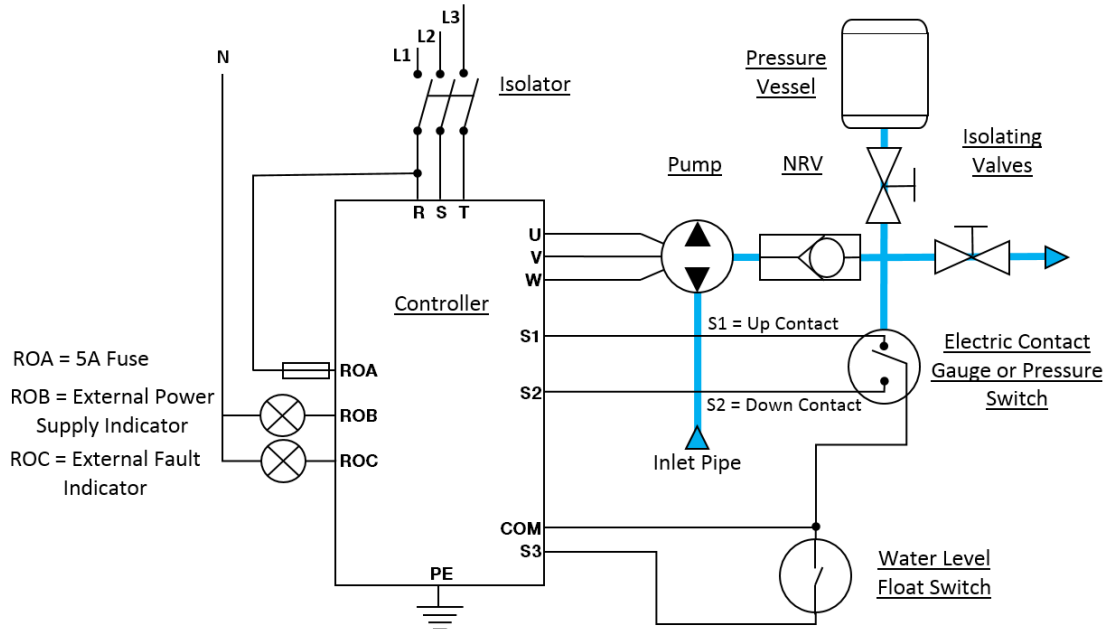

This example uses an Electric Contact Pressure Gauge or Pressure Switch in place of the transducer on the outlet side.

By utilising the acceleration and deceleration settings the controller will gently increase and decrease the pressure to achieve a desired pressure +/- variance

Adjust the switch cut-out and cut-in 0.2 – 0.4 bar each side of the desired running set point.
 e.g., 3 bar set point. Set cut out to 3.2- 3.4 bar. Set cut in 2.6 – 2.8 bar

b05.02	Set to 1	Selects Terminal S1, S2 Control
b02.08	Set to 0.0%	AI1 Feedback Lost Detecting Value. Not required.
b01.02	Recommended 20 sec	Low pressure running time.
b01.16	Set to 1	Restart after power on. Recommended.
b05.00	0 = Invalid 1 = NC 2 = NO	Set according to Terminal S3 switch type
b05.01	User to set	Sets S3 Action Delay Time in minutes
b05.03 b05.04	Recommend 20 sec or longer	Acc. and Dec. time. Use a value equal or greater than 20 sec to smooth pressure fluctuations

25. Application Example 7: Day Part run time

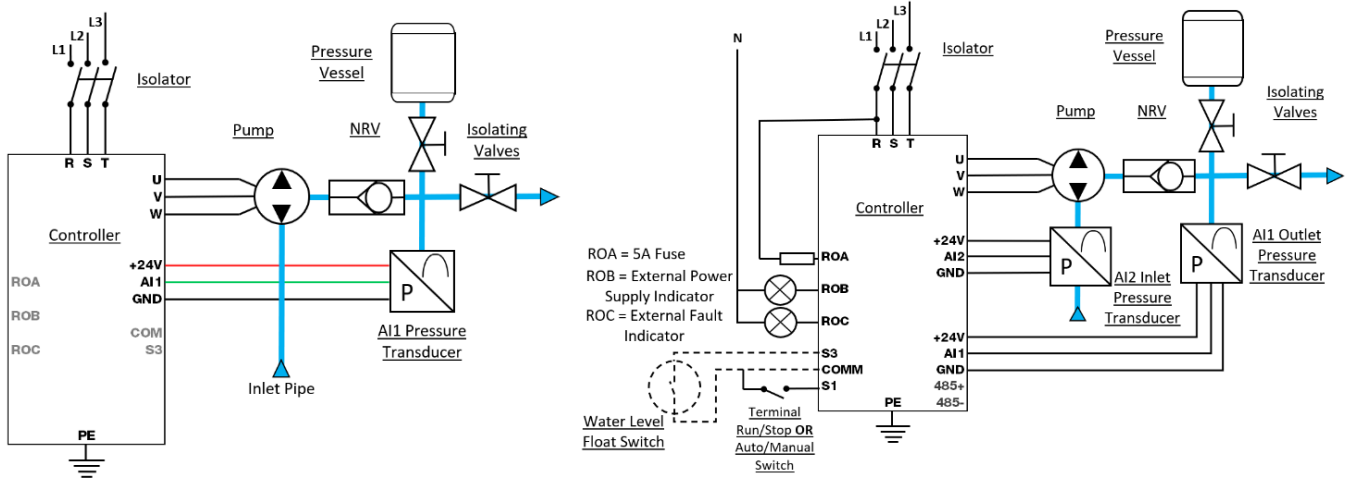

Day part run time allows the user to set varying conditions around operating pressure (and minimum inlet pressure) for pre-set periods of time.

Up to 3 time periods can be programmed.

An inlet pressure sensor is recommended but not essential. The configuration can be as simple as in Example 1. [Pg 16](#)

The controller has an inbuilt 24hr clock which runs when power is connected. For the clock to retain its time when there no power connected a battery must be fitted to the holder located on the uppermost PCB.

Do not fit a battery until you are ready to program DAY PART RUN TIME

The clock 'zero' hour' is the time the battery was fitted.

I.e. If the battery is fitted at 0800hrs the start and stop times must be calculated from this time.

Example: - Relevant Parameters on the following page.

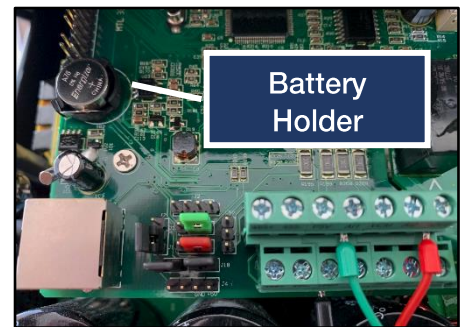

Day Part Run Time Example			
Clock 'zero' hour 0800 hrs			
Part A Start	1000 hrs	<i>Plus 02.00 hrs</i>	
Part A Stop	1300 hrs	<i>Plus 05.00 hrs</i>	
Set Point		2.5 bar	
Minimum inlet pressure		2.0 bar	
Part B Start	1400 hrs	<i>Plus 06.00 hrs</i>	
Part B Stop	1600 hrs	<i>Plus 08.00 hrs</i>	
Set Point		3.2 bar	
Minimum inlet pressure		2.3 bar	
Part A Start	2000 hrs	<i>Plus 12.00 hrs</i>	
Part A Stop	2330 hrs	<i>Plus 15.50 hrs</i>	
Set Point		3.5 bar	
Minimum inlet pressure		2.5 bar	
Default set point		3.0 bar	
Default minimum inlet pressure		1.8 bar	

Clock 'zero hour' – 0800hr

Day Part A: Run from 10am actual until 1pm actual at 2.5 bar.

Stop running if inlet pressure falls below 2.0 bar

Day Part B: Run from 2pm actual until 4 pm actual at 3.2 bar.

Stop running if inlet pressure falls below 2.3 bar

Day Part C: Run from 8pm actual until 11.30 pm actual at 3.5 bar.

Stop running if inlet pressure falls below 2.5 bar

Outside of these time periods, if there is water demand run at 3.0 bar.

Stop running if inlet pressure falls below 1.8 bar

To program the example from the previous page would require these settings:

br-07	Day Part Running Parameter Group
--------------	---

Address	Name	Setting Range	Factory Default	Description
b07.00	Day part Function Selection	0~3	0	Set to 3 = Day Part A, B and C
b07.01	Day Part A Starting Time	00.00~24.00 (hours)	0	Zero hour 0800. Start time 10 am actual Enter 02.00
b07.02	Day Part A Pressure setting	0~20 bar	3 bar	2.5 bar
b07.03	Day Part A Finish Time	00.00~24.00 (hours)	0	Zero hour 0800. Finish time 1 pm actual Enter 05.00
b07.04	Day Part A AI2 Lower Limit Tuning	0~20 bar	2 bar	2.0 bar
b07.05	Day Part B Starting Time	00.00~24.00 (hours)	0	Zero hour 0800. Start time 2 pm actual Enter 06.00
b07.06	Day Part B Pressure setting	0~20 bar	3 bar	3.2 bar
b07.07	Day Part B Finish Time	00.00~24.00 (hours)	0	Zero hour 0800. Finish time 4 pm actual Enter 08.00
b07.08	Day Part B AI2 Lower Limit Tuning	0~20 bar	2 bar	2.3 bar
b07.09	Day Part C Starting Time	00.00~24.00 (hours)	0	Zero hour 0800. Start time 8 pm actual Enter 12.00
b07.10	Day Part C Pressure setting	0~20 bar	3 bar	3.5 bar
b07.11	Day Part C Finish Time	00.00~24.00 (hours)	0	Zero hour 0800. Finish time 11.30 pm actual Enter 15.50
b07.12	Day Part C AI2 Lower Limit Tuning	0~20 bar	2 bar	2.5 bar
b00.01	Operating pressure value	0.0~100.0	3.0 bar	Set to required value for the pressure desired outside of the day part timings. For this example the setting would be 3 bar
b07.13	Lower limit of inlet pressure	0~20 bar	0.0 bar	Valid all day. The controller will shut down the pump if the inlet pressure falls below this value. 0.0 bar = invalid For this example the setting would be 1.8 bar
b01.11 to b01.13				If required, calibrate/tune the AI2 inlet transducer. It is not essential to have an inlet sensor fitted but if none is installed b07.04 , b07.08 , b07.12 and b07.13 require a 0.0 value entered

The Day Part run time is useful in pressure boosting applications with variable incoming water supply pressure or for process applications where a different set point is desirable for a regular but limited part of the day.

It can be utilised for irrigation applications to coincide with zone timings where, due to friction losses, zone size or elevation, a different pressure is required to achieve equivalent performance from the spray nozzle.

Another possibility is where there are storage tanks at a higher elevation. The system timings can be set to ensure that tank is filled at a certain time that doesn't interfere with the 'normal' system operating pressure.

26. Minimum Frequency Considerations

For the unit to successfully shut down into sleep mode it is essential that the pump can achieve the operating set point pressure **b00.01** at the minimum Hz value **b05.07** minus the Sleeping Test Frequency Proportion/Water Testing setting **b04.02**.

One method to establish the lowest frequency is to close the discharge valve fully.

The controller will slow the pump to the speed at which it can maintain the operating pressure.

These values can be seen on the display by cycling between Running Hz and Operating Pressure.

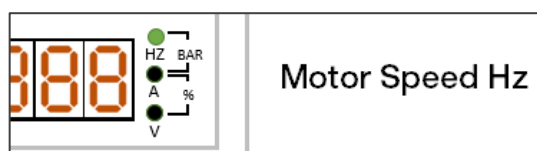

Pump Affinity Laws state that flow is directly proportional to Pump Speed whereas Pressure is proportional to the Square of Pump Speed.

This means that any change to speed will have a greater influence on flow rates than to pressure.

Note that for a 50Hz pump:

48Hz is a 4% reduction in speed from 50Hz. 45Hz is a 9% reduction in speed from 50Hz.

30Hz is a 40% reduction in speed. The pump will only develop approx. 36% of its rated pressure.



Typically, fan cooled electric motors should not operate under 20Hz unless forced cooling is fitted.

27. Multi Pump Control Wiring

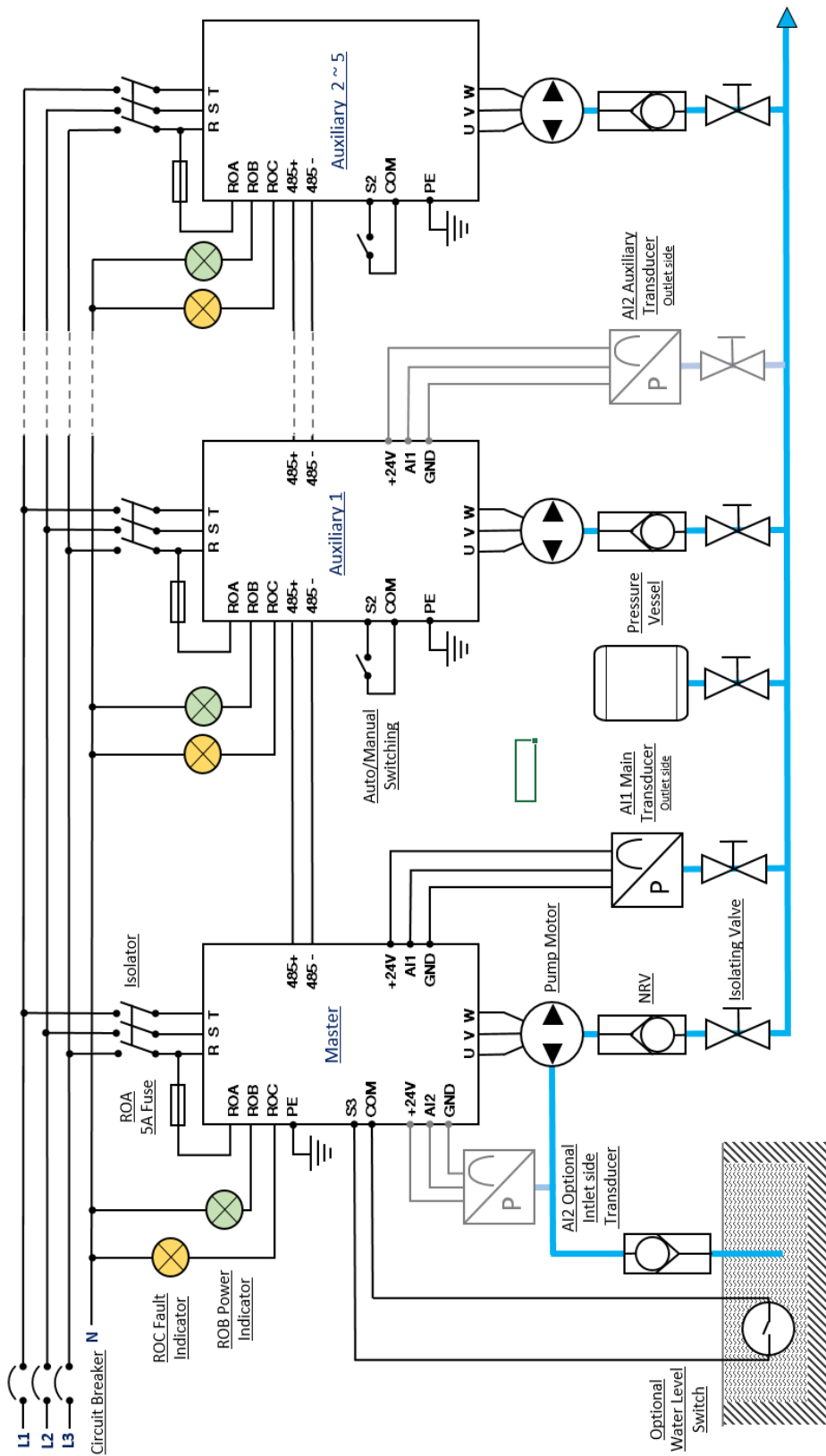

28. Multi Pump Control Programming

Master Controller Setup

b08.01 to b08.05	Set pump motor nameplate details for the motor connected to this controller	Enter motor parameters as per the motor nameplate Note: To enter group br08 requires a password at b07.15 Default password is 65535
b00.02	Motor rotating direction	Set according to the wiring. Check the pump rotates in the forward direction
b03.00	Communication address	Master controller only - Set as 00. Default is 02
b03.08	Number of auxiliary controllers	Enter the number of auxiliary controllers
b01.05	AI1 Transducer range	Enter the maximum range (bar) of the connected transducer
b01.08	Digital/Analogue display tuning	If the controller display reads less than the analogue gauge, decrease b01.08 If the controller display reads more than the analogue gauge, increase b01.08
b05.02	Terminal Run/Stop	If terminal Run/Stop control is desired, connect to and program the master controller only as per Group br05 Pg 34 . After programming, press RUN to set the controller to operational mode.
Set according to the installation specifics		
b00.01	Operating Pressure	Set according to the desired duty point
b01.00	High Water Pressure Alarm	Prevent system damage caused by excessive water pressure. Must be set 1 bar above operating pressure
b01.01	Low Water Pressure Alarm	Prevent pump damage caused by low inlet pressure or dry run
b01.16	Restart after Power on	0 = Invalid 1 = Valid
b01.17	Running mode select	0 = Synchronous control mode 1 = Master/Slave
b05.00	Water level switch (if fitted)	0 = Invalid 1 = NC valid 2 = Invalid
b05.10	Alternating time	Set to balance the service time of all pumps
br-07 Group	Day Part Run time	Detailed explanation at Section 25 Pg 21 and 22
b00.03	Anti-freeze function	Set if the pump is installed in a situation below freezing temperature
b03.09	Fault shift function In the event of a master controller fault, control shifts to a nominated auxiliary.	Factory default 2 (single controller use)= Invalid Set Master controller as 0 to validate Fault shift requires a backup transducer connected to the Aux1 controller AI1 input



Turn page for Auxiliary controller programming.

28. Multi Pump Control Programming Con't

Auxiliary Controller Setup

b08.01 to b08.05	Set pump motor nameplate details for the motor connected to this controller	Enter motor information as per the motor nameplate
b00.02	Motor rotating direction	Set according to the wiring. Check the pump rotates in the forward direction
b03.00	Communication address	Set according to the auxiliary status Set Aux 1 as 1, Aux 2 as 2 etc.
b03.08	Number of auxiliary controllers	Enter the number of auxiliary controllers
b02.08	AI1 Feedback lost Detecting Value	It is not essential to connect an output side pressure sensor. If fault shift b03.09 is valid, for nominated Auxiliary Controller #1, leave parameter at default 1.0 If no standby AI1 output side pressure sensor is fitted set parameter to 0.0
b03.09	Fault shift function	Only applicable if Fault shift function on the master controller is valid For the controller nominated at b03.00 as the #1 auxiliary <u>only</u> , set b03.09 to value =1. For any additional auxiliary controllers leave the setting at factory default = 2

Terminal Run/Stop and Auto/Manual Switching

It may be desirable to have remote run/stop switching fitted

Connect a switch between S1- COM using shielded twisted pair wiring

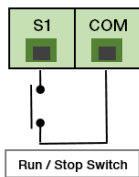

Terminal Run/Stop Control Wiring

S1-COM (On): Run

S1-COM (Off): Stop

Instructs the control to enter or exit automatic operation

Manual control can also be connected between S2 – COM on master or auxiliary controllers. This function is particularly useful for manual pipe fill operations

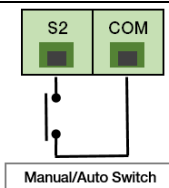

Manual/Auto Control Wiring

S2-COM (On): Manual Control (pump runs at max Hz b05.06)

S2-COM (Off): Auto Control (normal VFD operation)

Note: After exiting Manual control it is necessary to press the run button to resume automatic operation

29. Application Example 8: 'Pumping' Applications

By altering parameter **b02.02** the PID logic to the AI2 input is inverted and a level sensor can be used to control pumping. This is ideal for drainage applications or for maintaining water levels.

The start and stop level can be set and an alarm level can be selected.

The pump speed can be set for the levels utilizing the minimum Hz **b05.07** in the low level range and maximum Hz **b05.06** settings to apply above the upper level.

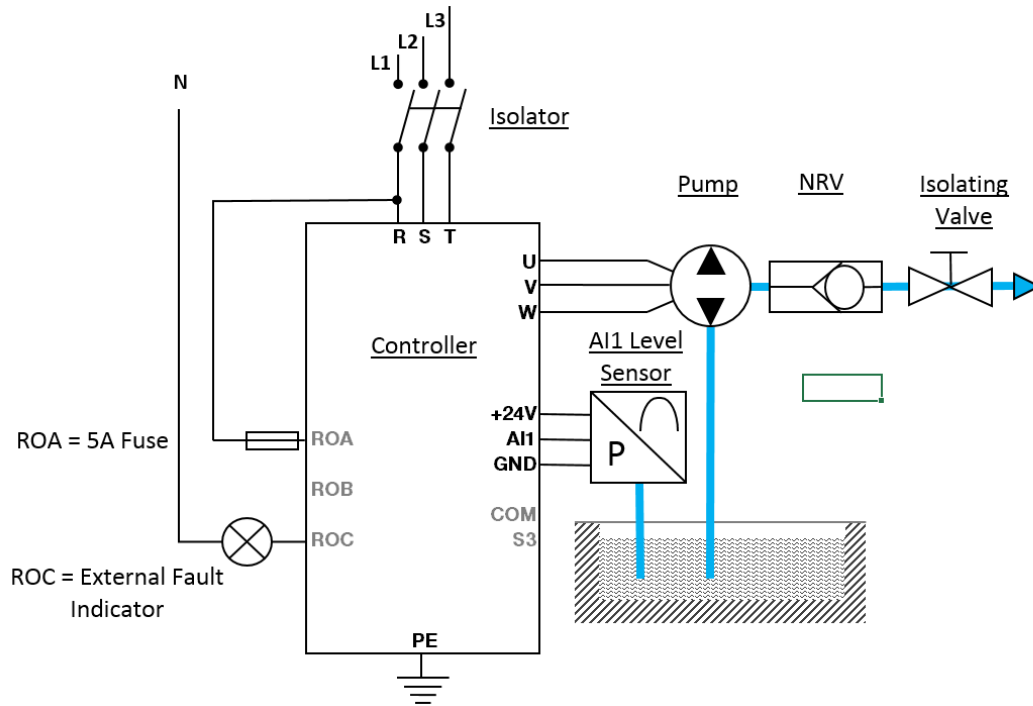

b02.02	Set to 1	PID output characteristics 1 = Pumping
b01.05	Set to 100 (%)	Set as range of water level transmitter
b01.00	As required In Water Supply Mode this is the High Water Pressure setting	Set as High-Level alarm value (% of b01.05)
b01.01	As required In Water Supply Mode this is the Low Water Pressure setting	Set at Low level alarm value. (% of b01.05) Below this % the pump will stop running Above this % the pump operates at Min Hz b05.07
b00.01	As required In Water Supply Mode this is the Operating Pressure setting	Full Frequency pumping water level Above this % the pump operates at Max Hz b05.06 Below this % (but above the stop value of b01.01) the pump operates at Max Hz b05.07
b01.02	As required Unit - Seconds	Low Level Running time. Default 10 sec Delay time before shutting down when a LowLevel Condition is detected
b05.09	As required Unit - Hours	Low level restart delay time in hours In the event of the pump stopping due to a Low-Level condition, this is the delay time before the pump attempts to restart. If a manual restart is preferred set to 0

<p>b01.06 and b01.08</p>	<p>If required</p>	<p>Water level transmitter calibration.</p> <p>b01.06 to adjust transducer zero bias b01.07 N/A for this application b01.08 AI1 Upper limits Settings to adjust the display value to correspond with an analogue reading</p> <p>Controller display reading less than gauge: decrease higher limit (b01.08)</p> <p>Controller display reading higher than gauge: increase higher limit (b01.08)</p>
----------------------------------	--------------------	--

When the sensor level reading rises above Low Level Alarm Value **b01.01** and the low level restart delay has passed, the pump will switch on and run at minimum Hz.

The Pump speed increases to Maximum Hz when sensor level reading rises above the Operating Pressure (Level) value **b00.01**

The Pump switches off and triggers the alarm circuit when sensor level reading rises to the High Level Alarm Value **b01.00**

Connecting the relay output **ROC** to an external source or indicator is strongly recommended to provide clear warning of a non-running fault condition.

When the sensor level reading drops below Low Level Alarm Value **b01.01** the pump will switch off after the delay time set at **b01.02** is exceeded.

Example:

Pumping wastewater or for drainage - fitted with a level control transducer

- Controller set so with the water level above 40%, pumping occurs at full-frequency
- Below 40%, the pump speed reduces to the minimum frequency setting
- Below 10% of maximum level the pump stops

30. Programming Groups and Parameter Details

br-00 Application Group

Address	Name	Setting Range	Factory Default	Description
b00.00	Unit password	0 ~ 65535	65535	Password to enter programming mode. <i>Password can be altered at b06.09</i>
b00.01	Operating pressure value	0.0~100.0	3.0 bar	This value can be altered without entering programming mode by pressing the UP or DOWN buttons on the display
b00.02	Motor direction	0 or 1	0	0 = Forward 1 = Reverse
b00.03	Freeze-proofing	0 or 1	0	Used in cold areas 0 = Invalid 1 = Valid
b00.04	Anti-clogging	0 or 1	0	0 = Invalid 1 = Valid
b00.05	Anti-clogging rotation time	0.0~300.0 seconds	20.0	Once this setting is Valid, when the pump shuts down a sequence runs the pump in reverse and then forward at a set speed and for a set time. To prevent harm, ensure the frequency is within the operational specification of the pump. Parameter (b01.04) allows you to set the FWD/REV transition time
b00.06	Anti-clogging rotational frequency	0.00~600.00 Hz	15.00Hz	

br-01 Running Parameter Group

Address	Name	Setting Range	Factory Default	Description
b01.00	High Water Pressure OR Level Alarm Value	0.0~100.0 bar	8.0 bar	If pressure exceeds the pre-set value the pump halts, alarms and displays HP High pressure alarm must be at least 1 bar greater than the operating pressure set point
b01.01	Low Water Pressure OR Low Water Level Alarm Value	0.0~100.0 bar	0.5 bar	Low water pressure settings prevent damage due to dry run or limited water supply When pressure falls below the Low Water Pressure setting (b01.01) for longer than the Low Pressure Run Time (b01.02) the pump halts, alarms and displays LP
b01.02	Low Pressure and/or Low Level Run time	0~60 seconds	20 sec	
b01.03	Minimum Freeze-proofing Frequency	1.00 ~ 30 Hertz	05.00Hz	Valid when b00.03 is set to 1. Runs with this setting in event of freezing if pump in sleep-down mode.
b01.04	Anti-clogging FWD/REV dead time	0.0~3600.0 seconds	1.0 sec	When Anti Clogging (b00.04) is valid this setting is the FWD/REV transition time
b01.05	Maximum transducer range	0.0~100.0	10.0 bar	Set according to the transducer maximum pressure rating i.e. 10.0 = 10 bar. 16.0 = 16 bar

br-01 Running Parameter Group continued

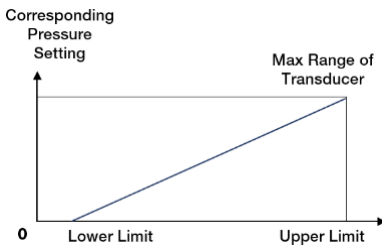
b01.06	AI1 Lower limit	0.00~10.00 Volts	1.00V	Use lower limit settings to ensure Transducer Zero Value (When using current input, 4~20mA corresponds to 1~5V)
b01.07	AI1 Lower limit tuning	-100~100%	0%	
b01.08	AI1 Upper limit	0.00~10.00 Volts	5.00V	Use Upper limit settings match controller display with an associated gauge
b01.09	AI1 Upper limit tuning	-100~100%	100%	<i>Hint: Tuning is much simpler with the pump at a constant speed. Temporarily set the minimum and maximum frequency the same. This prevents the pump from 'hunting'</i> Run at low pressure output and adjust the low end of the scale
b01.10	AI1 filtering time	0.00~10.00 sec	0.10 sec	
b01.11	AI2 Lower limit	0.00~10.00 Volts	1.00V	Run the pump near full pressure to adjust the top end of the scale
b01.12	AI2 Lower limit tuning	-100~100%	0%	
b01.13	AI2 Upper limit	0.00~10.00 Volts	5.00V	Controller display reading less than gauge: decrease higher limit (b01.08 and/or b01.13)
b01.14	AI2 Upper limit tuning	-100~100%	100%	Controller display reading higher than gauge: increase higher limit (b01.08 and/or b01.13)
b01.15	AI2 filtering time	0.00~10.00 seconds	0.10 sec	<p>Relationship of Transducer Parameter Setting</p> <p>If an analogue input experiences interference, a longer Filtering Time will improve signal reliability but at the expense of sensitivity</p> 
b01.16	Restart after Power On	0 or 1	0	0: Invalid 1 = Valid
b01.17	Control mode	0 or 1	1	0 = Synchronous (default) 1= Master/Slave

br-02 PID Parameter Group

Address	Name	Setting Range	Factory Default	Description
b02.00	PID source	0 or 1	0	0 = Keypad 1= Communication
b02.01	PID Feedback source	0, 1 or 2	0	0 = AI1 (main input) 1= Reserved
b02.02	PID Output	0 or 1	0	0 = Water Supply 1 = Pumping
b02.03	Proportional Gain (Kp)	0.00~100.0	2.50	Determines the strength of the PID regulation. Regulation is stronger with a higher Kp but more fluctuation occurs
b02.04	Integral time (Ti)	0.01~10	1.00 sec	Bias between the Feedback and the Given, determining the speed of regulation. A shorter Ti achieves greater regulation

br-02 PID Parameter Group Continued

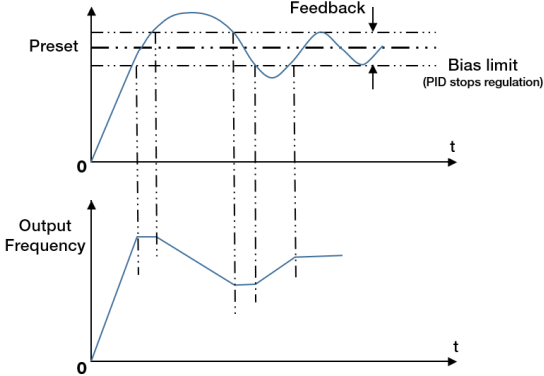
b02.05	Differential time (Td)	0.00~10	0.00 sec	<p>Variable ratio between the Feedback and the Given.</p> <p>A longer Td achieves greater regulation. Differential regulation amplifies interference of the system</p>
b02.06	Sampling Cycle (T)	0.01~100.00 or 1	0.10 sec	<p>Sampling Time. An increased value results in a sluggish response</p>
b02.07	PID Control Bias Limit	0.0~100%	0.00%	<p>Max Bias of PID output value corresponding to closed loop given value.</p>  <p>Correctly set this value helps regulate the accuracy and stability of PID system.</p>
b02.08	AI1 Feedback lost Detecting Value	0.0~100.0%	1.0%	<p>Transducer Fault Detecting Setting Value corresponding to full range (100%)</p> <p>When the detecting time exceeds Feedback lost time the controller interprets this as a transducer malfunction.</p> <p>The System will shut down and display E022 Transducer Fault Code</p> <p>If an inlet transducer is connected to AI2 change b02.09 to 1.0%</p>
b02.09	AI2 Feedback lost Detecting Value	0.0~100.0%	0.0%	
b02.10	Feedback lost detecting Time	0.00~360.0 sec	1.00 sec	

br-03 Multi Pump Control Parameter Group

Address	Name	Setting Range	Factory Default	Description
b03.00	Communication address	0 to 31	02	Single Controller only use value 02 Multiple controllers 00 = Master 01 ~ 05 Auxiliary Controllers 06 ~31 Reserved
b03.01	Baud Rate Selection	0 to 5	3	Data of master and auxiliary comes into the rate 0 = 1200BPS 1 = 2400BPS 2 = 4800BPS 3 = 9600BPS 4 = 19200BPS 5 = 38400BPS
b03.02	Data Format	0 to 5	0	Data Format (Parity Check)
b03.03	Communication Delay Time	0 to 200 ms	15ms	Interval of Data responding
b03.04	Communication Timeout Delay	0.0 to 100.0 seconds	0.0 s	If the interval time exceeds the setting value the unit will report E018 as fault. 0.0 = Invalid
b03.05	Communication Error Action	0 and 1	0	0 = Halt and alarm 1 = Don't alarm and continue
b03.06	Communication response time	0 and 1	0	0 = Responding to Write Operation 1 = Un-responding to Write Operation
b03.07	Data transmission Time Interval	0.05 to 2.00 seconds	0.10s	Long setting will slow data transmission. Short time setting will increase mistakes
b03.08	Auxiliary Quantity	0 to 5	0	0 = no auxiliary Fitted
b03.09	Fault Shift in event of Master Controller Fault	0 to 2	2	Factory default 2 (single controller use) = Invalid Set Master controller as 0 Set Auxiliary Controller as 1 Fault shift requires Aux1 controller to be connected to a backup transducer

br-04 Sleeping Function Parameter Group

Before proceeding, check the total number of parameters in group Br04 and use the correct table.

- Legacy software range Br00-00 to Br00-04
- Current software range Br00-00 to Br00-06

Legacy Software

Address	Name	Setting Range	Factory Default	Description
b04.00	Sleep Function	0 or 1	1	No Demand Auto stop 0 = Invalid 1 = Valid
b04.01	Sleeping wait time	0.0~300.0 seconds	5.0 sec	Delay time before entering sleep cycle
b04.02	Sleeping Test Frequency Proportion	0~100%	4%	Determines the frequency to ensure sleep down once water demand ceases. Value corresponds to the rated frequency If Rated Frequency = 50Hz x 4% = 2Hz. 1% - 4% is typical
b04.03	Wake up pressure bias	0.0~20.0 bar	0.5 bar	Pressure drop to initiate pump wake-up. Pressure Set Point (b00.01) minus Wake Up Pressure Bias (b04.03) equals Pump Restart Pressure
b04.04	Sleep Bias	0.0~1.0 bar	0.0	The pressure fluctuation which allows sleeping

Current Software

Address	Name	Setting Range	Factory Default	Description
b04.00	Sleep Function	0 or 1	1	No Demand Auto stop 0 = Invalid 1 = Valid
b04.01	Sleeping wait time	0.0~300.0 seconds	5.0 sec	Delay time before entering sleep cycle
b04.02	Water testing	0 - 1000	150	Sleep detection factor
b04.03	Start up deviation	0.0 – 20.0	0.5 bar	Allowable pressure drop during sleep before wake up
b04.04	Sleep Bias	0.0~1.0 bar	0.1 bar	The pressure fluctuation which allows sleeping
b04.05	Sleep trial cycle	0 - 36000 seconds	20.0 sec	Sleep trial interval time cycle
b04.06	Wake Up delay	0 - 36000 seconds	0	Wake up delay time

br-05 Control Parameter Group

Address	Name	Setting Range	Factory Default	Description
b05.00	Water Level Control (Input S3)	0,1 or 2	2	Water level switch (float) control 0 = Invalid 1 = NC 2 = NO Display will read LL when operation interrupted
b05.01	S3 Action Delay Time	0~300 minutes	1min	Delay to prevent excessive stop/start due to level switch fluctuations or slow source water recharge
b05.02	S1 and S2 Terminal Control	0 to 3	2	0 = Invalid 1 = Electric contact control (i.e. double adjustable pressure switch) S1-COM (On): Acceleration S2-COM (On): Deceleration 2 = Manual/Auto control S2-COM (Off): Auto Control S2-COM (On): Manual Control 3 = Terminal Run/Stop S1-COM (On): Run S1-COM (Off): Stop S2-COM (Off): Auto Control S2-COM (On): Manual Control Auto control – Constant water pressure control mode (b00.01) Manual control = Full frequency Running (b05.05)
b05.03	Acceleration time	0.1~3600 seconds	Model Set	Time to accelerate from zero to Max Hz Suggest minimum setting 5 sec for surface mounted pumps. 1 sec for borehole motors
b05.04	Deceleration time	0.1~3600 seconds	Model Set	Time to decelerate from Max (b05.06) to minimum Hz (b05.07) Suggest min 5 sec for surface mounted pumps. 1 sec for borehole motors
b05.05	Maximum Output Frequency	10.00~60.00 Hertz	50.00Hz	Determines the acceleration/deceleration rate
b05.06	Upper limit of Output Frequency	00.00 (b05.05) setting	50.00Hz	Maximum running frequency
b05.07	Lower threshold of Output Frequency	00.00~600.00 Hertz	20.00Hz	Minimum frequency limit to ensure high efficiency operation. Note: Ensure the pump is able to maintain the Operating Pressure Value (b00.01) at minimum Hz (b05.07)
b05.08	Carrier Frequency	1.0~15.0k Hertz	Model Set 08.0	Use to ameliorate motor noise and controller interference to the surroundings. A high Carrier Frequency reduces motor noise but leads to greater temperature rise and additional interference The user is discouraged from altering this setting.

br-05 Control Parameter Group continued

b05.09	Low Pressure (LP) Restart Delay Time	0.0~600.0 hours	0.0	If b05.09 = 0 then auto restart after a low pressure fault is invalid Restart delay if the controller shuts down after sensing a low pressure condition
b05.10	Alternating time	0.00~300.00 hours	8.00 hours	In the event of multiple pumps operating as Master/Slave configuration, in order to balance and prolong the pump service life set the parameter value. The master and auxiliary pump switches over according to the time set 0.0 = Invalid

br-06 Interface Parameter Group

Address	Name	Setting Range	Factory Default	Description
b06.00	Running status Display Selection	0~0x01F	0x01F	Bit 0: Operational Frequency Bit 1: Pressure tested value Bit 2: Pressure setting value Bit 3: Output Current Bit 4: Busbar voltage Bit 5: Output voltage Bit 6: Present time Bit 7: Pump Inlet Pressure Bit 8: Master Sending Frequency
b06.01	Stop status Display Selection	0~0x01F	0x00F	Bit 0: Pressure setting value Bit 1: Pressure tested value Bit 2 Setting Frequency Bit 3 Busbar voltage Bit 4: Input terminal status Bit 5: Output terminal status Bit 6: AI1 Input voltage Bit 7: Pump Inlet Pressure Bit 8: Present time
b06.02	Keypad Display Selection	0 to 3	3	0 = External Keypad Prior Enable 1 = Both Display enable, Only external keypad Control 2 = Both Display enable, Only on-board keypad Control 3 = Both Display enable and Keypad control
b06.03	Relay Output Selection	0 to 4	0	0 = Error or External fault 1 = Forward Running 2 = Frequency Reaching 3 = Stop Status 4 = Lower Limit of Output Frequency reaching

br-06 Interface Parameter Group continued – Fault codes

b06.04	3 rd last Fault			E000: Fault Free E001: INU U Phase Protection E002: INU V Phase Protection E003: INU W Phase Protection E004: Acceleration OC E005: Deceleration OC E006: Constant velocity OC E007: Acceleration OV E008: Deceleration OV E009: Constant velocity OV E010: Busbar Under-voltage E011: Motor Overload E012: Controller Overload E013: Input phase failure E014: Output phase failure E015: Rectifier Module Overheat E016: Inversion Module Overheat E017: External fault E018: Communication Fault E019: Current sense fault E020: Reserved E021: EEPROM Operation fault E022: Transducer Fault E023: Reserved E023: Reserved E044: Hardware acceleration overcurrent E045: Hardware deceleration overcurrent E046: Hardware constant speed overcurrent
b06.05	2 nd last Fault			
b06.06	Latest Fault To erase faults: b07.14 Enter 2		Read only	

b06.07	Parameters Storage Condition	0, 1 or 2	0	0 = Power off storage 1 = Power off default storage 2 = Invalid
b06.08	Accumulated Running time	0~65535 hours	Read only	Display accumulated running time <i>65535 hrs = 2730 days = 7.48 years</i>
b06.09	Set programming password for (b00.06)	0~65535	65535	Password required to enter programming mode.

br-07 Day Part Running Parameter Group

Address	Name	Setting Range	Factory Default	Description
b07.00	Day part Function Selection	0~3	0	0 = Invalid 1 = Day Part A 2 = Day Part A and B 3 = Day Part A, B and C
b07.01	Day Part A Starting Time	00.00~24.00 (hours)	0	<p>The controller has a built in 24hr clock function. To retain the time setting it is necessary to fit a battery to the uppermost PCB</p> <p>The clock 'zero hour' commences from the time the battery is fitted. I.e. if the battery is fitted at 10am, the start and finish time are calculated from 10am.</p> <p>If the battery is fitted at 2pm, the start and finish time are calculated from 2pm.</p> <p>Setting Starting and Finishing Time to 0 = invalid</p> <p>Day part pressure setting determines the steady state value of the output pressure for this time period irrespective of the setting at b00.01</p> <p>If the inlet pipe pressure falls below the Lower Limit Tuning (pressure value) the pump will stop until the inlet pressure rises again</p> <p>The Lower Limit Tuning value can be set to 0 to invalidate this control method</p>
b07.02	Day Part A Pressure setting	0~20 bar	3.0 bar	
b07.03	Day Part A Finish Time	00.00~24.00 (hours)	0	
b07.04	Day Part A AI2 Lower Limit Tuning	0~20 bar	2.0 bar	
b07.05	Day Part B Starting Time	00.00~24.00 (hours)	0	
b07.06	Day Part B Pressure setting	0~20 bar	3.0 bar	
b07.07	Day Part B Finish Time	00.00~24.00 (hours)	0	
b07.08	Day Part B AI2 Lower Limit Tuning	0~20 bar	3.0 bar	
b07.09	Day Part C Starting Time	00.00~24.00 (hours)	0	
b07.10	Day Part C Pressure setting	0~20 bar	3 bar	
b07.11	Day Part C Finish Time	00.00~24.00 (hours)	0	
b07.12	Day Part C AI2 Lower Limit Tuning	0~20 bar	2 bar	
b07.13	Lower limit of inlet pressure	0~20 bar	0.0 bar	Valid all day. The controller will shut down the pump if the inlet pressure falls below this value. 0.0 bar = invalid
b07.14	Restore defaults	0, 1 or 2	0	0 = No action 1 = Set to default (does not apply to all parameters – use with care) 2 = Clear error record
b07.15	Password to enter Group br08	0~65535		Set by b08.06 . Default for b08.06 is 65535

br-08 Motor Parameter Group

Group br-08 is locked behind an additional password

Go to **b07.15** and enter the password set at b06.09 (Default password is 65535)

This is the same password used at b00.00 to enter the programming menu.

Then exit to Level two and proceed to Group **br08**

Address	Name	Setting Range	Factory Default	Description
b08.00	G/P Option	0 or 1	0	0 = G Model 1 = P Model
b08.01	Motor rated Power	0.4~350 kW	Model Set	Enter settings from the motor nameplate The Over Voltage OV and Over Current OC protection are derived from the values entered in parameters b08.01 – b08.05
b08.02	Motor rated Frequency	0.01~600 Hertz	50Hz	
b08.03	Motor rated Speed	0~36000 RPM	Model Set	
b08.04	Motor rated Voltage	0~460 Volts		
b08.05	Motor Rated Current	0.1~2000.0 Amps		
b08.06	Password for br07.15	0~65535	65535	The password for b07.15 can be given a unique value. Alter only with care and ensure a record of the password change is retained securely
b08.07	Password of Factory Parameters	0~65535	XXXXXX	Do not alter this value. Abnormal operation or damage could result 12840

Pump power ratings are most commonly referenced from the P2 (Shaft Power) rating.

The Controller interacts with the motor so the b08.01 value should be the P1 rating.



Programming should only be carried out by suitably trained personnel.

Parameters randomly modified or altered in error can induce abnormal operation and have the potential to harm the controller as well as the water supply system, or even to cause personal injury or accidents.

If the controller is behaving in an unusual manner it is highly possible that a parameter has been altered in error. In this event, navigate through each Group and every Parameter, resetting to factory default values.

Afterwards recommence programming from the very beginning.

Keeping a record of programmed parameter values is highly recommended and will assist fault finding.

31. Controller Error Code Trouble Shooting Guide

Code	Fault Type	Reason	Solution
E001	IGBT ph-U fault Out1	Acc/Dec time is too short.	Increase ACC/Dec time. Check external equipment and eliminate interference. Check grounding.
E002	IGBT ph-V fault Out2	IGBT module fault. Malfunction caused by interference.	
E003	IGBT ph-W fault Out3	Poor grounding.	
E004	Over current when accelerating OC1	Acc time is too short. Overloading. Low input voltage. Controller undersized.	Increase Acc time. Check the power supply. Consider a higher output controller.
E005	Over current when decelerating OC2	Dec time is too short. Overloading. Controller undersized.	Increase Dec time. Consider a higher output controller.
E006	Over current when constant speed OC3	Sudden load change. Low input voltage. Controller undersized.	Check the power supply. Consider a higher output controller.
E007	Over voltage when accelerating OV1	High input voltage. Regenerative energy from the motor is too great.	Check the power supply. Avoid restarting the motor until it is stationary.
E008	Over voltage when decelerating OV2	High input voltage. Dec time is too short. Overloading.	Increase Dec time. Check the power supply.
E009	Over voltage when constant speed running OV3	High input voltage. Overloading.	Check input voltage. Consider a higher output controller.
E010	DC Bus under voltage UV	Low input voltage.	Check the input power supply.
E011	Motor Overload OL1	Low input voltage. Improper overload protection threshold on motor. Motor is undersized.	Check the power supply. Ensure rated current of motor set correctly. Check the motor is correctly sized.
E012	Controller Overheat OL2	Acc time too short. Motor restart when decelerating. Low input voltage. Overloading.	Increase Acc time. Ensure motor stops completely before restarting. Check the power supply. Consider a higher output controller.
E013	Input phase failure	Input power supply open phase.	Check wiring, installation and power supply.
E014	Output phase failure SPO	Open phase on the output side.	Check wiring, installation and motor.

32. Controller Error Code Trouble Shooting Guide Con't

E015	Rectifier overheat OH1	Sudden over-current.	
E016	IGBT Overheat OH2	Input/Output side has short circuit. Controller cooling fans damaged or failed. Carrier frequency too high. Heatsink ineffective - cooling fins blocked. Ambient temperature too high. Loose wires or connections. Auxiliary power supply unit damaged or low driving voltage for IGBT Power module bridge damaged. Control board faulty.	Refer to measures of over-current. Check all wiring and connectors. Replace the cooling fans. Clean the heat sink- remove all dust etc. Decrease the carrier frequency. Take measures to lower ambient temperature where controller is mounted.
E017	Reserved		
E018	Communication fault		Check communication devices and signals. Set correct Baud Rate. Press STOP/RST to reset. Replace controller.
E019	Current detection Fault ITE	Loose wires or connections to control board Auxiliary power supply is damaged Current detector is damaged or abnormal amplifying circuit	Check all wiring and connectors. Replace controller.
E020	Reserved		
E021	EProm Fault	R/W fault of control parameters	Press STOP/RST to reset. Replace controller.
E044	Hardware acceleration over current	Acc time too short. Low input voltage. Pump not rotating freely	Lengthen the Acc time Check the power supply. Check the motor and pump
E045	Hardware deceleration over current	Dec time too short. Pump not rotating freely	Lengthen the Dec time. Check the motor and pump
E046	Hardware constant speed over current	Low input voltage. Pump not rotating freely	Check the power supply. Check the motor and pump

Note: If the display freezes with the message **B803** isolate the incoming power then disconnect the cooling fans from the PCB.

A faulty cooling fan can prevent the drive from completing its boot cycle successfully

33. Faults and Trouble Shooting Guide

LP	Low water Pressure	Insufficient water in-flow Motor rotating in the wrong direction	Check the pressure transmitter installation Check the motor direction Ensure parameter b01.01 is not set too high Check the system for non-pump or controller issues
HP	High Water Pressure	Parameter b01.00 is too small Back pressure affecting system	Check the pressure transmitter installation Ensure parameter b01.00 is not set too low AND is at least 1 bar higher than the operating set point. Check the system for non-pump or controller issues
LL	Low water Level	Occurs if a sensor is connected to Terminal S3	Displays if the sensor connected to Terminal S1 is registering a low reading. In the case of a float, ensure parameter b05.00 is set according to NC or NO condition
E022	Sensor Fault	Pressure transmitter disconnected or Pressure transmitter short circuit. PID feedback disappears	Check the pressure transmitter Check the cable between the controller and the pressure transmitter Check wiring. Red = 24V Green = AI1 Black = Gnd Check the PID feedback source b02.01 Check settings b02.08 to b02.10
EXXX Faults	A list of EXXX faults is on Pg 36 - Parameter Group br06 Detailed explanations on Pg 39 - 40 - Section 32		

Symptom	Possible Cause	Suggested solution
Controller won't enter sleep mode	Wrong Parameter Leaks on output side of the system NRV leakage Pressure tank damaged High EMI environment	Check b04.00 is valid (setting 1) Alter (increase) b04.04 Sleeping bias Check Pressure tank. Re-pressure or replace as required Ensure transducer wiring is shielded. Shield layer connects to PE
Display Pressure error	Sensor error Wrong Parameters Transducer wires too long	Fault check sensor and consider replacement Calibrate b01.05, b01.08 Shorten transducer wiring
Continuous full frequency running	Lost pressure feedback signal Wrong Parameters Pump under sized	Check transducer and wiring Check b05.02 (auto/manual) setting is correct S2 COM should be open Consult pump performance curve and verify the pump selection is correct
Pressure slow to stabilise	PID value unmatched Acc/Dec time too fast Delay on pressure feedback	Tune PID value b02.03, b02.04 Tune Acc/Dec time b05.03, b05.04 Ensure transducer isn't located at a distance from the pump
Motor Noise	Motor faulty Motor installation not stable Low Carrier Frequency	Check the motor Increase Carrier Frequency b05.08

34. Maintenance

- Maintenance must be performed according to designated maintenance methods
- Maintenance must be performed by authorized personnel only
- After turning off the main circuit power supply, please wait for 5 minutes before starting work or opening the controller cover
- DO NOT directly touch components or devices on PCB board without taking suitable precautions. The controller can be damaged by static electricity
- After maintenance, all screws must be tightened

1. Controller	Ensure there is no abnormal vibration, heat noise or smell coming from the controller
2. Fans	Ensure fans are working and in good condition and that air speed and airflow are normal
3. Motor	Remain alert to abnormal vibration, noise, heat or for any open phase problems

Periodic Maintenance

Operation can suffer if the controller suffers over-heating. Ambient temperature should be maintained in the range 0-40 deg C and humidity between 20 to 90%.

Over the life of the controller, a build-up of dust or dirt can result in the controller operating at a higher temperature than normal.

The controller should be installed where airborne dust is minimised.

The cover should be removed periodically and vacuum or low pressure air used to remove any build-up of dust or dirt especially on the PCB's, on the fans and on the cooling plate/heatsink fins.

While the cover is removed, check the control terminal screws are tight.

The iDrive controllers are fitted with cooling fans to assist with controlling temperature. If the operation of the fan is compromised or the fan has failed, abnormal operation will result.

- Fans and capacitors are considered wearing parts.
- Expected fan life = 20,000 hours running. (Check accumulated run time at **b06.08**)
- Expected capacitor life = 30 – 40,000 hrs running,
- Abnormal appearance, colour or smell indicates that the capacitor should be replaced

Cooling fans should be replaced every 2 years.

Replace the capacitors every 5 years.

Replacement fan Part Numbers	Bia iDrive 3220	807596	50 x 50mm	1 of
	Bia iDrive 3400 to 3750	807597	60 x 60mm	2 of
	Bia iDrive 31100 to 31850	807597	80 x 80mm	2 of

35. Warranties – Terms and Conditions

This warranty is given in addition to the consumer guarantees found within the Australian Competition and Consumer Act 2010 (Cth) for goods purchased in Australia and the Consumer Guarantees Act 1993 NZ for goods purchased in New Zealand:



1) White International Pty Ltd / White International NZ Ltd (White International) warrant that all products distributed are free from defects in workmanship and materials, for their provided warranty period as indicated on the top or opposite side of this document. Subject to the conditions of the warranty, White International will repair any defective products free of charge at the premises of our authorised service agents throughout Australia and New Zealand if a defect in the product appears during the warranty period. If you believe that you have purchased a defective product and wish to make a claim under this warranty, contact us on our Sales Hotline on 1300 783 601, or send your claim to our postal address or fax line below and we will advise you as to how next to proceed. You will be required to supply a copy of your proof of purchase to make a claim under this warranty.

2) This warranty excludes transportation costs to and from White International or its appointed service agents and excludes defects due to non-compliance with installation instructions, neglect or misuse, inadequate protection against the elements, low voltage or use or operation for purposes other than those for which they were designed. For further information regarding the suitability of your intended application contact us on our Sales Hotline on 1300 783 601. If you make an invalid claim under this warranty, the original product will be sent back to you unrepaired.

3) This warranty refers only to products sold after the 1st January 2012, and is not transferable to another product type and only applies to the original owner, purchaser or end user, and is in addition to the consumer guarantees found within the Competition and Consumer Act 2010 (Cth) for goods purchased in Australia and the Consumer Guarantees Act 1993 (NZ) for goods purchased in New Zealand.

4) Our goods come with guarantees that cannot be excluded under the Australian Consumer Law. You are entitled to a replacement or refund for a major failure and for compensation for any other reasonably foreseeable loss or damage. You are also entitled to have the goods repaired or replaced if the goods fail to be of acceptable quality and the failure does not amount to a major failure. **2 YEAR WARRANTY**

5) To the fullest extent permitted by law, White International excludes its liability for all other conditions or warranties which would or might otherwise be implied at law. To the fullest extent permitted by law, White International's liability under this warranty and any other conditions, guarantees or warranties at law that cannot be excluded, including those in the Competition and Consumer Act 2010 (Cth), is expressly limited to: (a) in the case of products, the replacement of the product or the supply of equivalent product, the payment of the cost of replacing the product or of acquiring an equivalent product or the repair of the product or payment of the cost of having the product repaired, is at the discretion of White International or a 3rd party tribunal elected under the Competition and Consumer Act 2010 (Cth) for goods purchased in Australia and the Consumer Guarantees Act 1993 (NZ) for goods purchased in New Zealand; and

6) To the fullest extent permitted by law, this warranty supersedes all other warranties attached to the product or its packaging.

7) In the case of services, supplying the services again or the payment of the cost of having the services supplied again, is at the discretion of White International or a 3rd party tribunal elected under the Competition and Consumer Act 2010 (Cth) for goods purchased in Australia and the Consumer Guarantees Act 1993 (NZ) for goods purchased in New Zealand. 8) Our warranty commences from the date of purchase of the above mentioned pumps. Proof of purchase is required before consideration under warranty is given.

Record your date of purchase in the space below and retain this copy for your records.

Date of Purchase**Model Purchased**



www.whiteint.com.au

www.whiteint.co.nz

Please always refer to our website for further technical information & new product innovations

Disclaimer: Every effort has been made to publish the correct information in this manual. No responsibility will be taken for errors, omissions or changes in product specifications.

© 2024 Copyright White International Pty Ltd

TM ® - WARNING: Please be aware that various brands & products depicted within this document are subject to trademark, patent or design registrations. Infringement of any intellectual property contained within this document without express written authority by the appropriate intellectual property holder may result in further legal action to be taken. For any queries regarding use of the contained information please feel free to contact White International Pty Ltd.